

CHEHALIS INDUSTRIAL PARK

PORTIONS OF THE N.W. 1/4 AND THE S.W. 1/4 OF SEC. 11, TWN. 13 N., RG. 2 W., W.M.
LEWIS COUNTY, WASHINGTON

PRELIMINARY LANDSCAPE PLAN

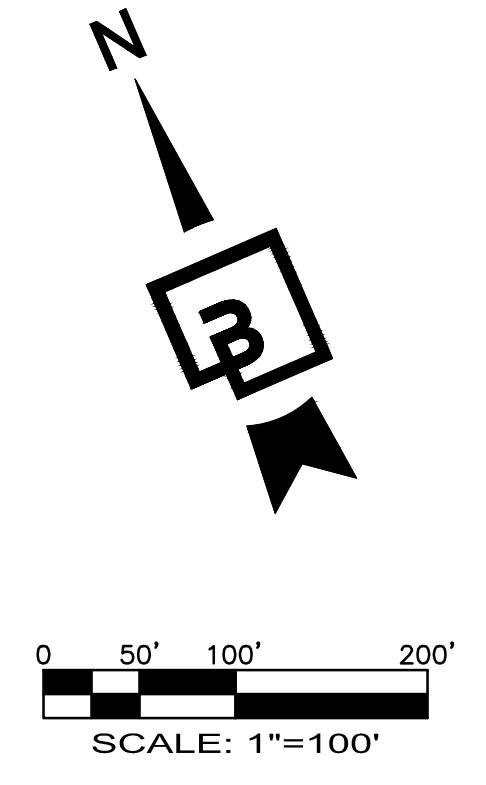
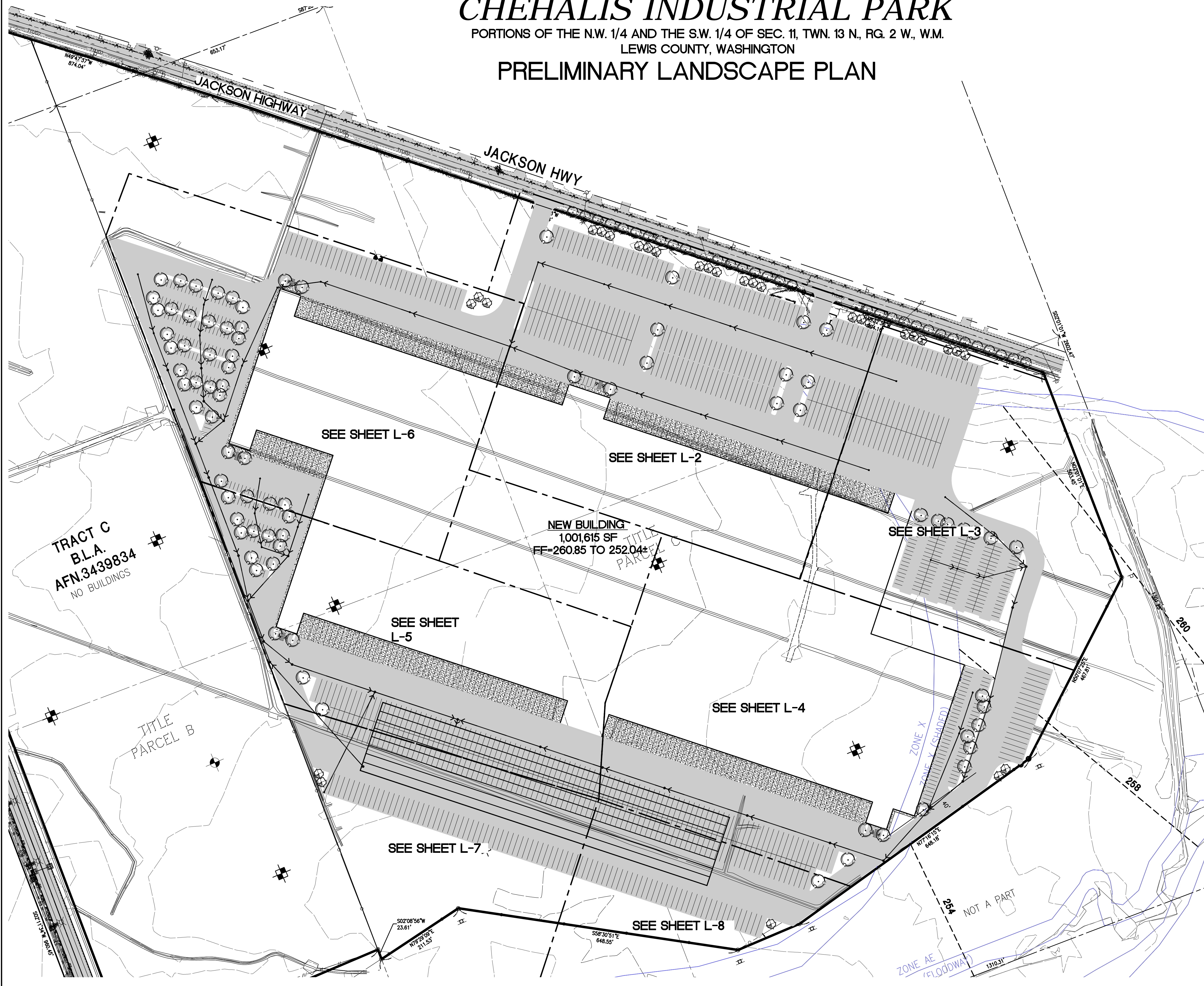

No.	Date	By	Chd.	Appr.	Revision

Title: **PRELIMINARY LANDSCAPE PLAN**
FOR
CHEHALIS INDUSTRIAL PARK

For: **PUGET WESTERN, INC.**
20000 N CREEK PARKWAY
BUILDING H
BOTHELL, WA 98011



Designed	JMV
Drawn	JMV
Checked	JMV
Approved	JMV
Date	9/2/21

Barghausen Consulting Engineers, Inc.
18215 72nd Avenue South
Kent, WA 98032
425.251.6222 barghausen.com

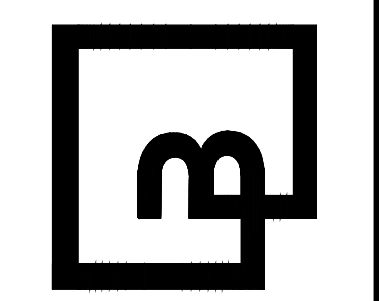

Job Number
14030
Sheet
L-1 of **9**

P:\14000a\14030\preliminary\14030-L.dwg 9/2/2021 11:40 AM JWIRLEY

CHEHALIS INDUSTRIAL PARK

PORTIONS OF THE N.W. 1/4 AND THE S.W. 1/4 OF SEC. 11, TWN. 13 N., RG. 2 W., W.M.
LEWIS COUNTY, WASHINGTON

PRELIMINARY LANDSCAPE PLAN

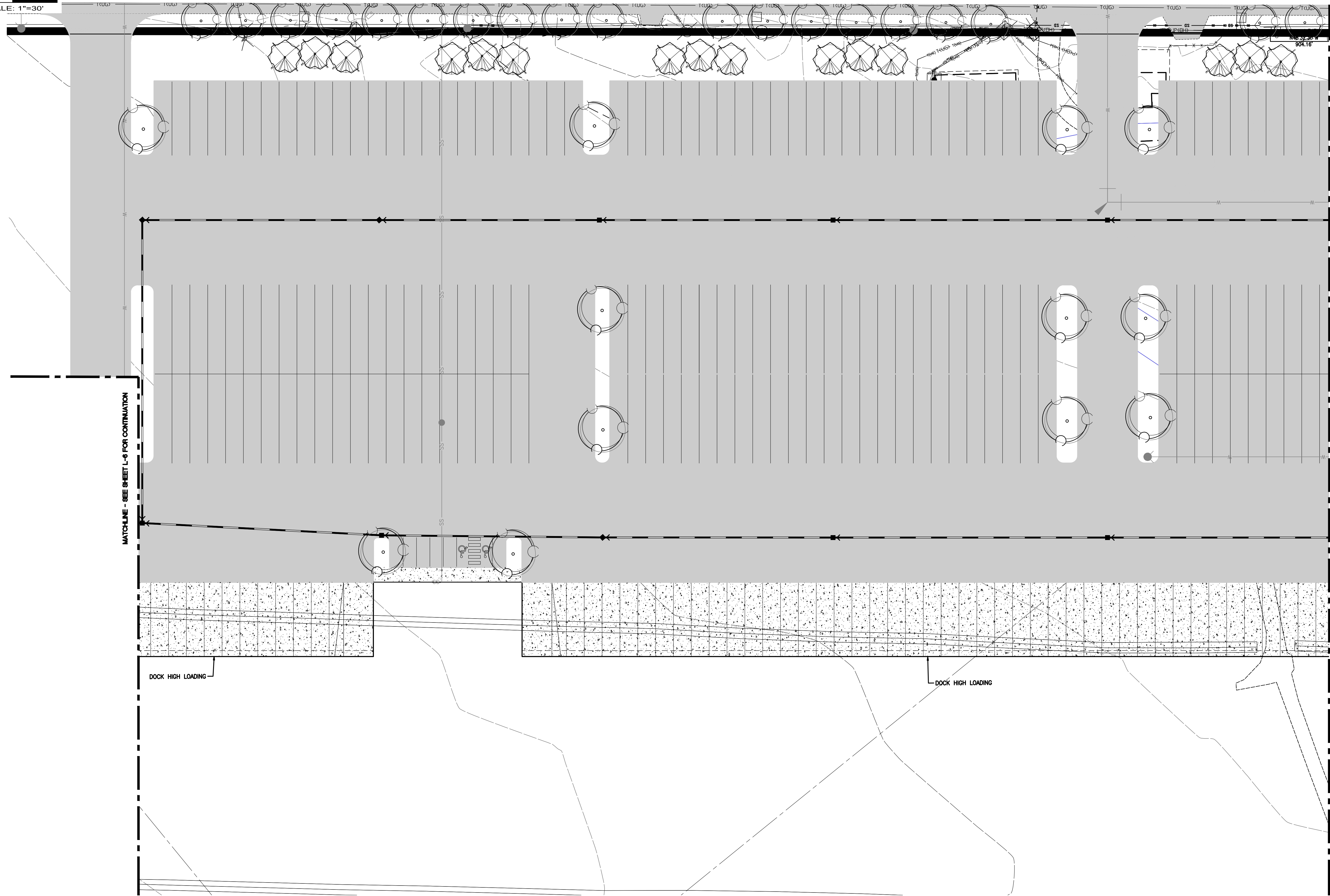
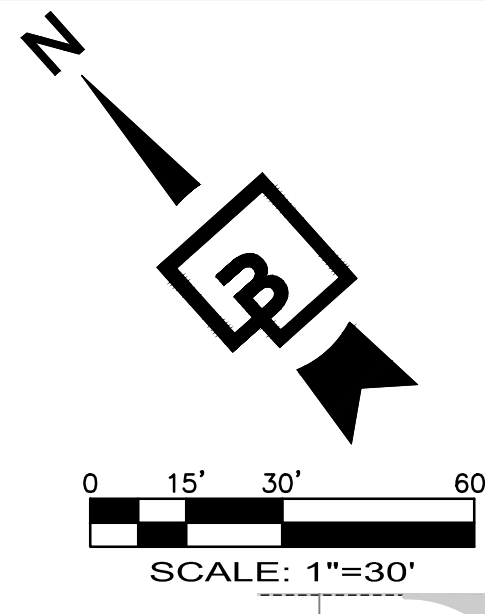

MATCHLINE - SEE SHEET L-8 FOR CONTINUATION

MATCHLINE - SEE SHEET L-2 FOR CONTINUATION

No.	Date	By	Chd.	Appr.	Revision

Title:
PRELIMINARY LANDSCAPE PLAN
FOR
CHEHALIS INDUSTRIAL PARK

For:
PUGET WESTERN, INC.
20000 N CREEK PARKWAY
BUILDING H
BOTHELL, WA 98011



Designed	JMV
Drawn	JMV
Checked	JMV
Approved	JMV
Date	9/2/21

Barghausen Consulting Engineers, Inc.
18215 72nd Avenue South
Kent, WA 98032
425.251.6222 barghausen.com

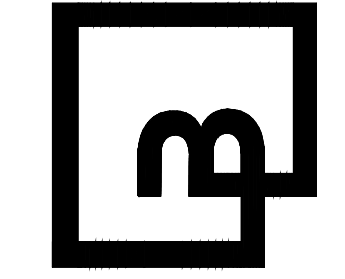

Job Number
14030
Sheet
L-2 of 9

CHEHALIS INDUSTRIAL PARK

PORTIONS OF THE N.W. 1/4 AND THE S.W. 1/4 OF SEC. 11, TWN. 13 N., RG. 2 W., W.M.
LEWIS COUNTY, WASHINGTON

PRELIMINARY LANDSCAPE PLAN

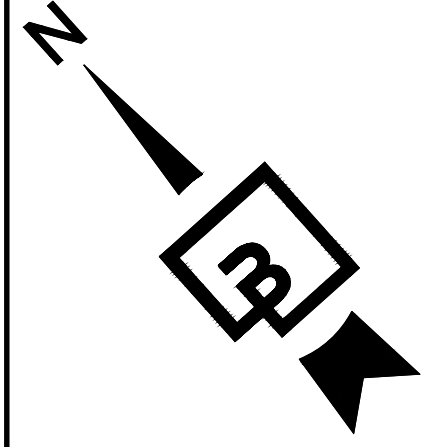

0 15' 30' 60'
SCALE: 1"=30'

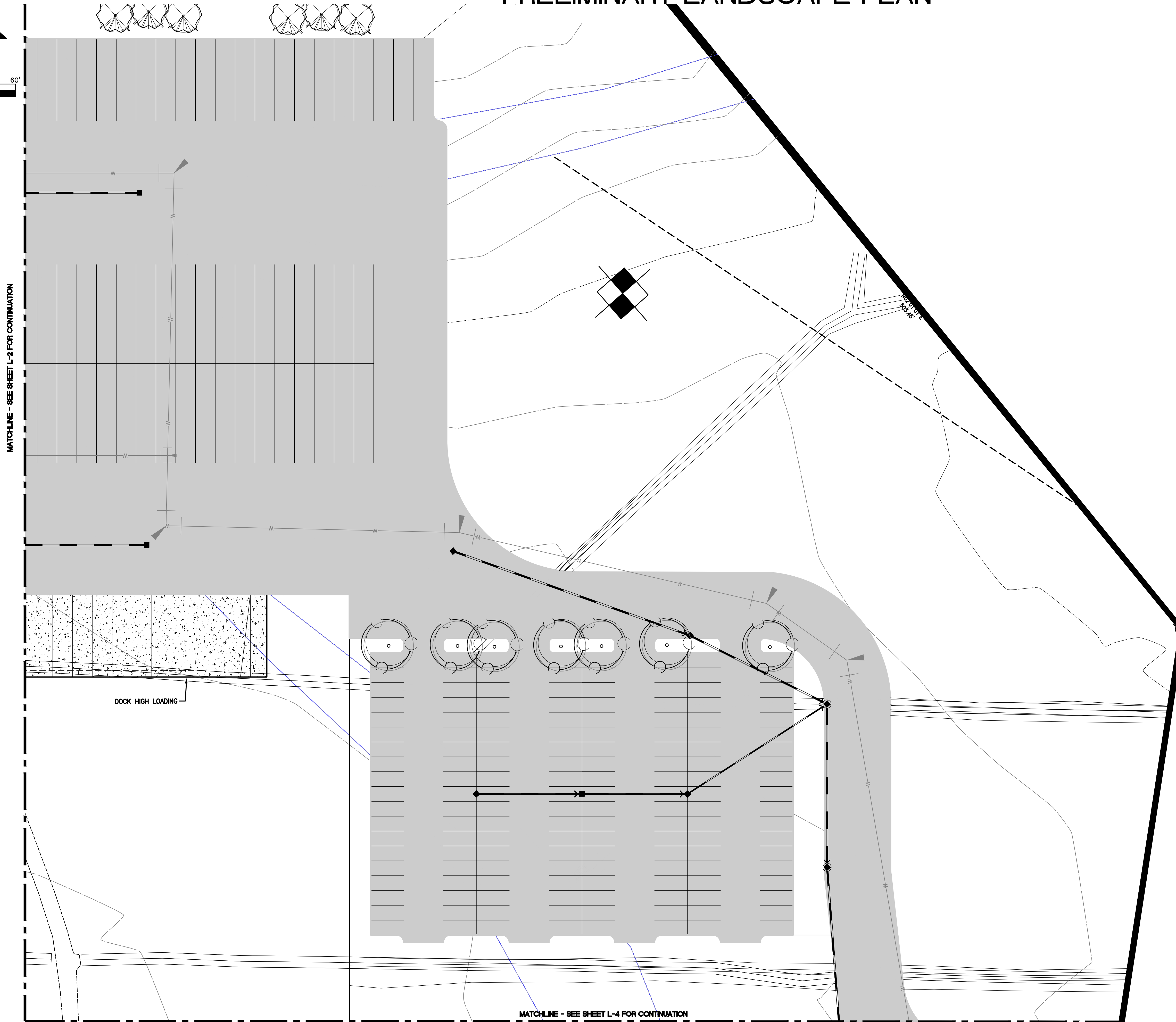

MATCHLINE - SEE SHEET L-2 FOR CONTINUATION

MATCHLINE - SEE SHEET L-4 FOR CONTINUATION

No.	Date	By	Chd.	Appr.	Revision

Title: **PRELIMINARY LANDSCAPE PLAN**
FOR
CHEHALIS INDUSTRIAL PARK

For: **PUGET WESTERN, INC.**
20000 N CREEK PARKWAY
BUILDING H
BOTHELL, WA 98011



Designed	JMV
Drawn	JMV
Checked	JMV
Approved	JMV
Date	9/2/21

Barghausen Consulting Engineers, Inc.
18215 72nd Avenue South
Kent, WA 98032
425.251.6222 barghausen.com

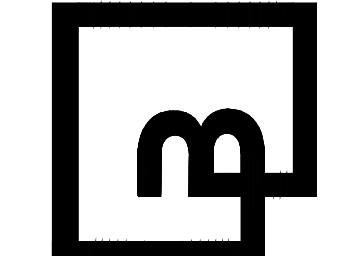

Job Number
14030
Sheet
L-3 of 9

CHEHALIS INDUSTRIAL PARK

PORTIONS OF THE N.W. 1/4 AND THE S.W. 1/4 OF SEC. 11, TWN. 13 N., RG. 2 W., W.M.
LEWIS COUNTY, WASHINGTON

PRELIMINARY LANDSCAPE PLAN

MATCHLINE - SEE SHEET L-3 FOR CONTINUATION

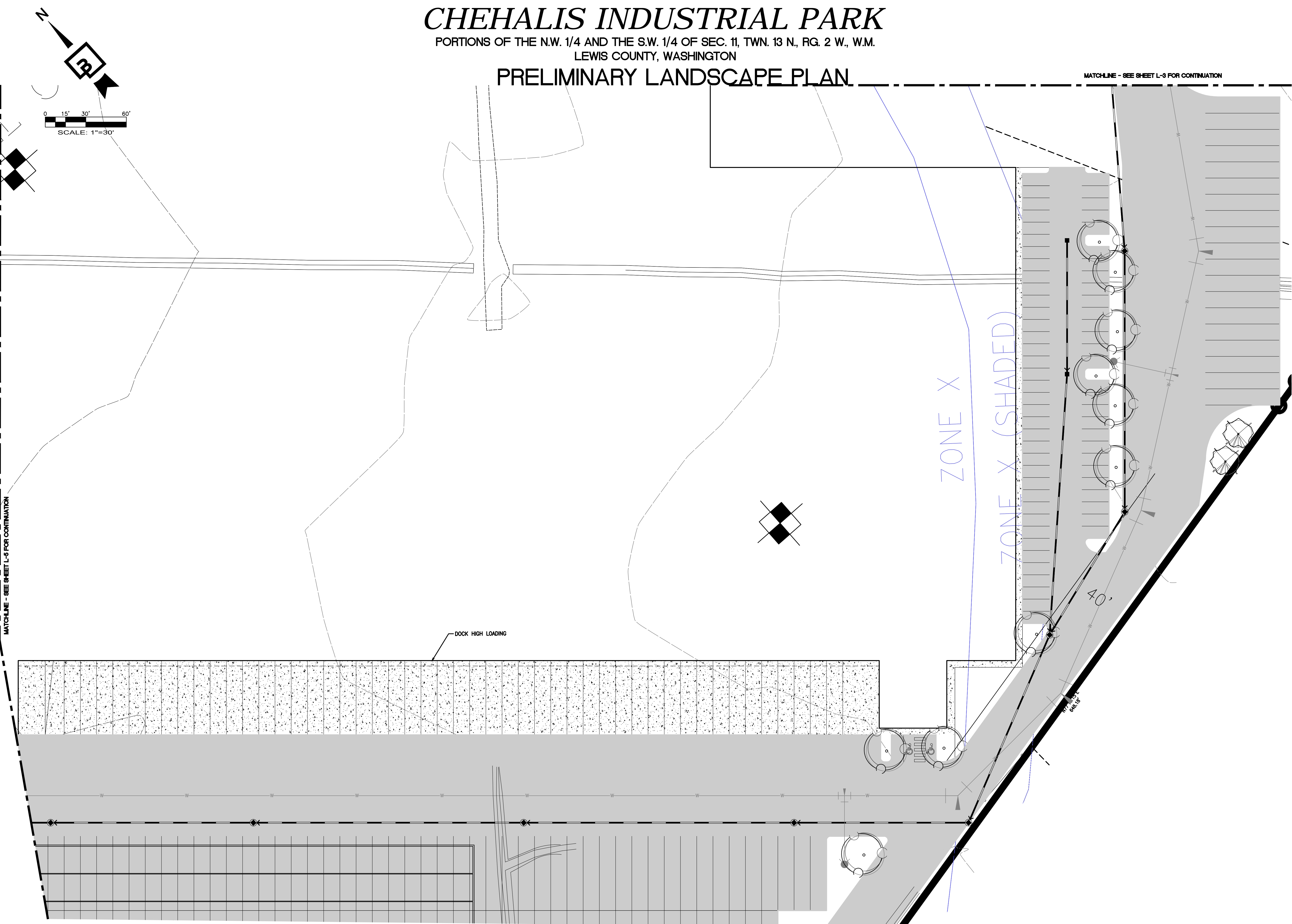

MATCHLINE - SEE SHEET L-3 FOR CONTINUATION



Job Number 14030	Sheet L-4 of 9	Barghausen Consulting Engineers, Inc. 18215 72nd Avenue South Kent, WA 98032 425.251.6222 barghausen.com		For:	PUGET WESTERN, INC. 20000 N CREEK PARKWAY BUILDING H BOTHELL, WA 98011	Title: PRELIMINARY LANDSCAPE PLAN FOR CHEHALIS INDUSTRIAL PARK
				Designed: JMV Drawn: JMV Checked: JMV Approved: JMV Date: 9/2/21	Scale: Horizontal: 1"=30' Vertical: N/A	

CHEHALIS INDUSTRIAL PARK

PORTIONS OF THE N.W. 1/4 AND THE S.W. 1/4 OF SEC. 11, TWN. 13 N., RG. 2 W., W.M.
LEWIS COUNTY, WASHINGTON

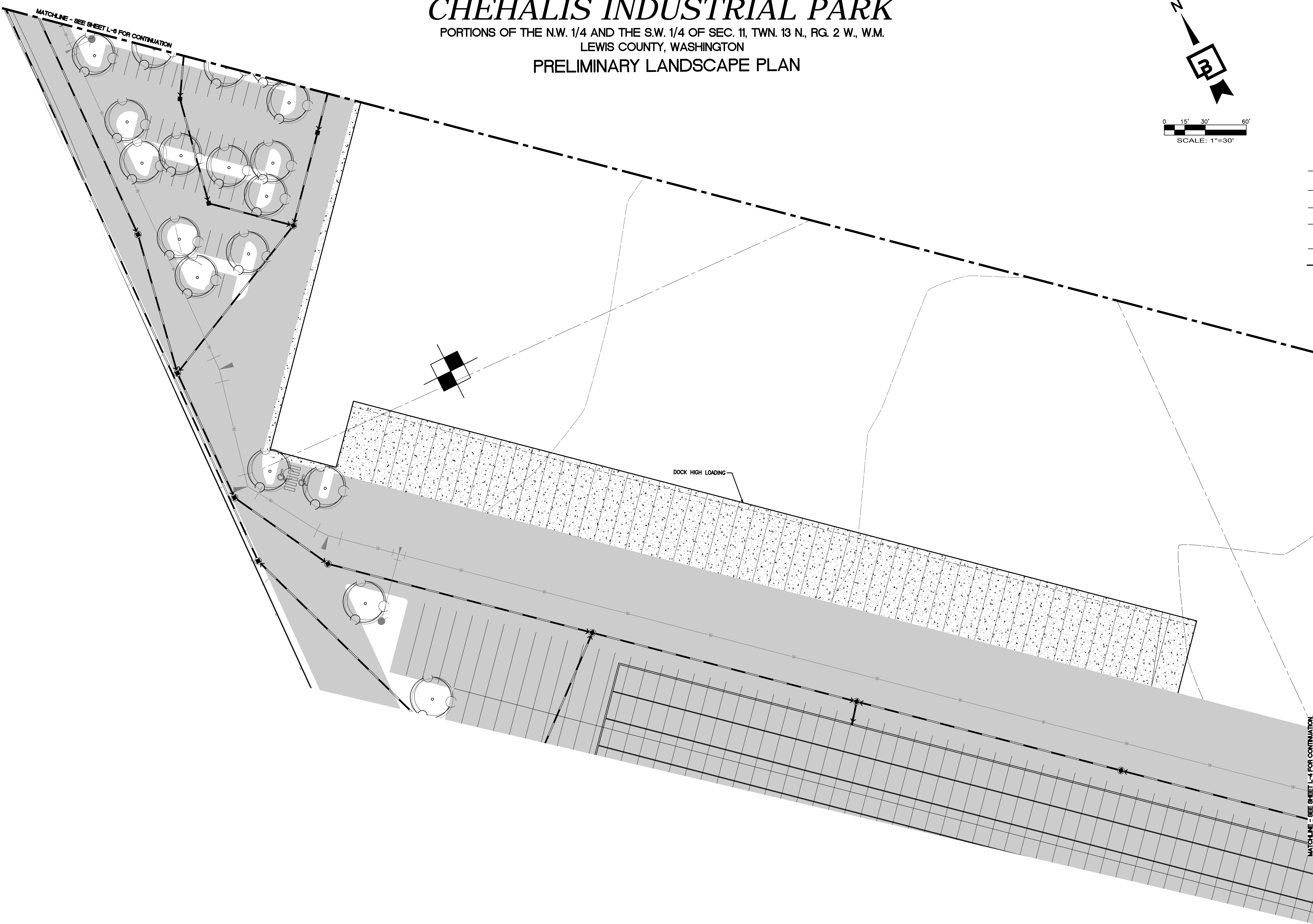
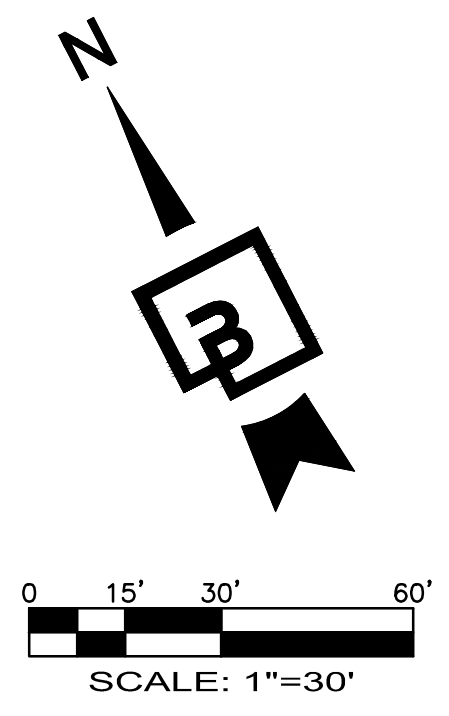
PRELIMINARY LANDSCAPE PLAN

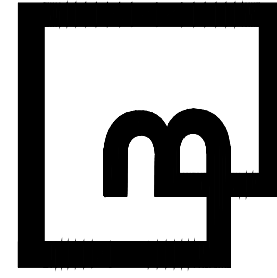

Job Number 14030	Sheet L-5 of 9	 Barghausen Consulting Engineers, Inc. 18215 72nd Avenue South Kent, WA 98032 425.251.6222 barghausen.com	Designed <u>JMV</u> Drawn <u>JMV</u> Checked <u>JMV</u> Approved <u>JMV</u> Date <u>9/2/21</u>	Scale: Horizontal 1"=30' Vertical N/A		For: PUGET WESTERN, INC. 20000 N CREEK PARKWAY BUILDING H BOTHELL, WA 98011	Title: PRELIMINARY LANDSCAPE PLAN FOR CHEHALIS INDUSTRIAL PARK
			No. Date By Cld. Appr. Revision				

P:\14000a\14030\preliminary\14030-L5.dwg 9/2/2021 11:40 AM JWARLEY

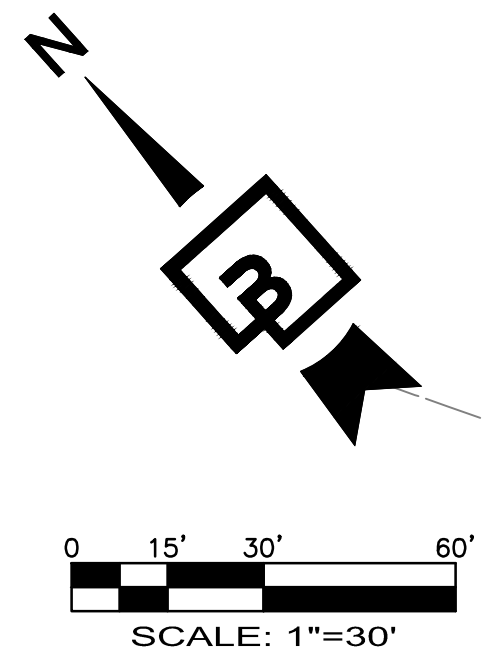

CHEHALIS INDUSTRIAL PARK

PORTIONS OF THE N.W. 1/4 AND THE S.W. 1/4 OF SEC. 11, TWN. 13 N., RG. 2 W., W.M.
LEWIS COUNTY, WASHINGTON

PRELIMINARY LANDSCAPE PLAN

MATCHLINE - SEE SHEET L-2 FOR CONTINUATION



No.	Date	By	Chd.	Appr.	Revision

Title:
PRELIMINARY LANDSCAPE PLAN
FOR
CHEHALIS INDUSTRIAL PARK

For:
PUGET WESTERN, INC.
20000 N CREEK PARKWAY
BUILDING H
BOTHELL, WA 98011



Scale:
Horizontal 1"=30'
Vertical N/A

Designed JMV
Drawn JMV
Checked JMV
Approved JMV
Date 9/2/21

Barghausen Consulting Engineers, Inc.
18215 72nd Avenue South
Kent, WA 98032
425.251.6222 barghausen.com

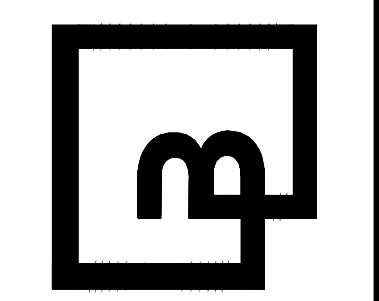

Job Number
14030
Sheet
L-6 of 9

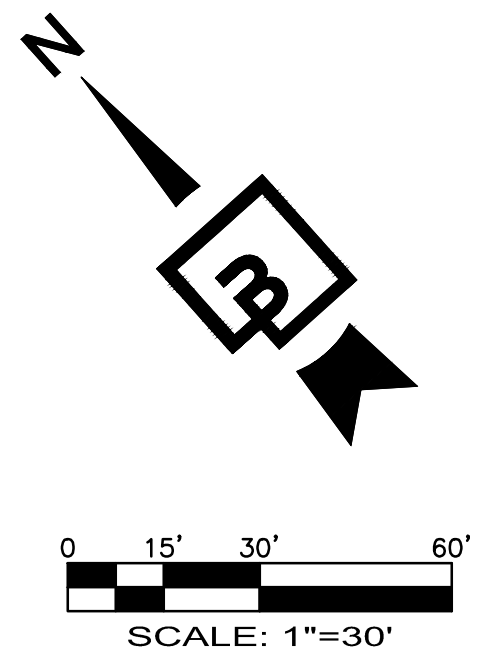

CHEHALIS INDUSTRIAL PARK

PORTIONS OF THE N.W. 1/4 AND THE S.W. 1/4 OF SEC. 11, TWN. 13 N., RG. 2 W., W.M.
LEWIS COUNTY, WASHINGTON

PRELIMINARY LANDSCAPE PLAN

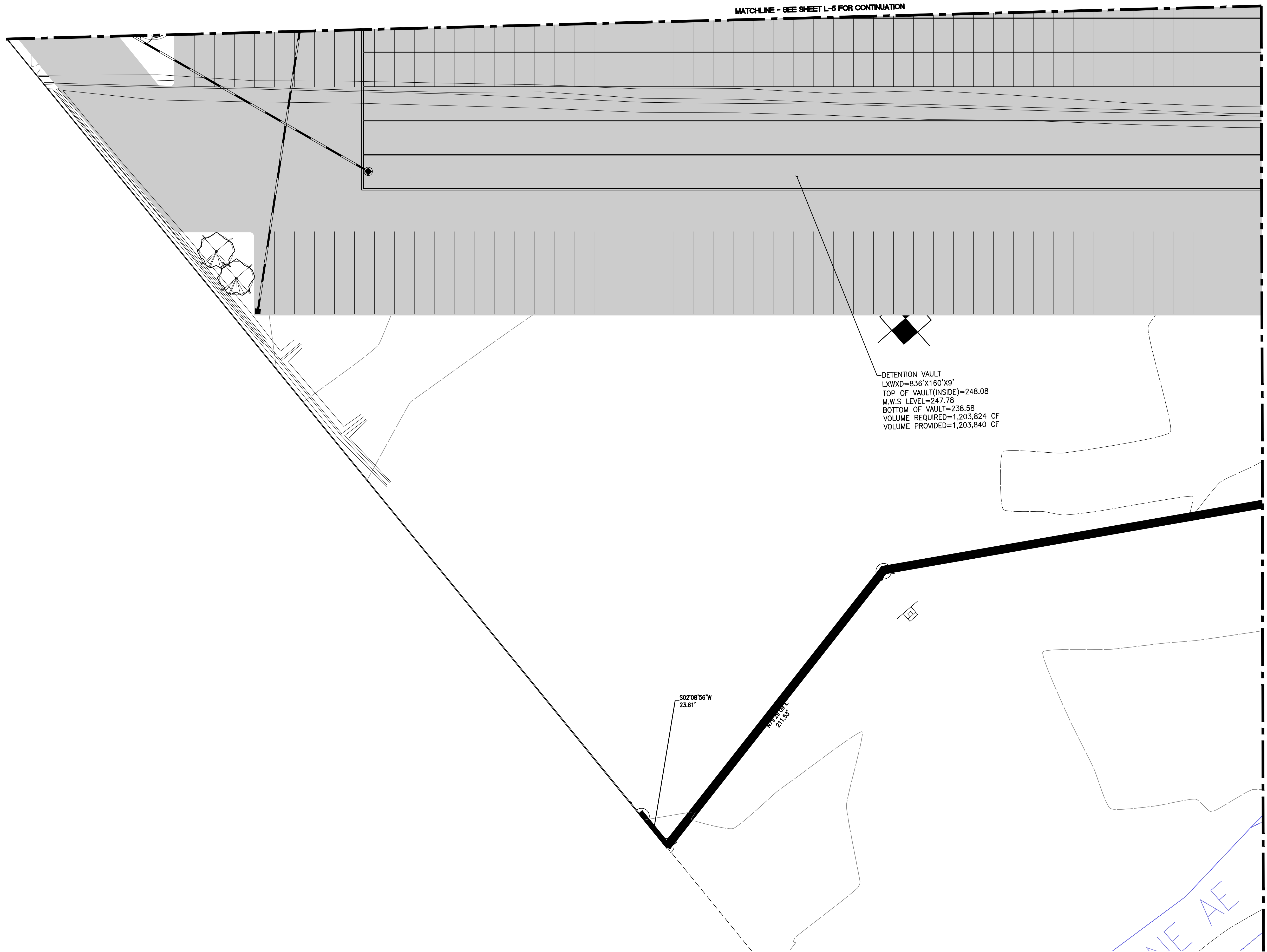

DETENTION VAULT
 L²W²D=836'X160'X9'
 TOP OF VAULT(INSIDE)=248.08
 M.W.S. LEVEL=247.78
 BOTTOM OF VAULT=238.58
 VOLUME REQUIRED=1,203,824 CF
 VOLUME PROVIDED=1,203,840 CF

MATCHLINE - SEE SHEET L-5 FOR CONTINUATION

MATCHLINE - SEE SHEET L-8 FOR CONTINUATION

Job Number
14030
 Sheet
L-7 of **9**

Barghausen Consulting Engineers, Inc.
 18215 72nd Avenue South
 Kent, WA 98032
 425.251.6222 barghausen.com

Designed JMV
 Drawn JMV
 Checked JMV
 Approved JMV
 Date 9/2/21

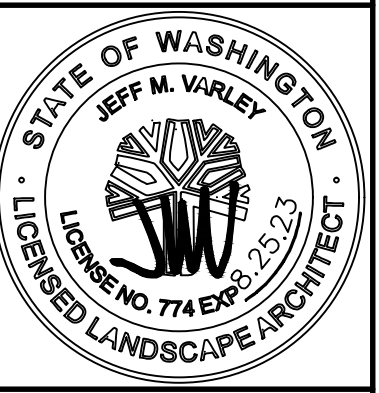

For:
PUGET WESTERN, INC.
 20000 N CREEK PARKWAY
 BUILDING H
 BOTHELL, WA 98011

No.	Date	By	Ckd.	Appr.	Revision
					PRELIMINARY LANDSCAPE PLAN FOR CHEHALIS INDUSTRIAL PARK

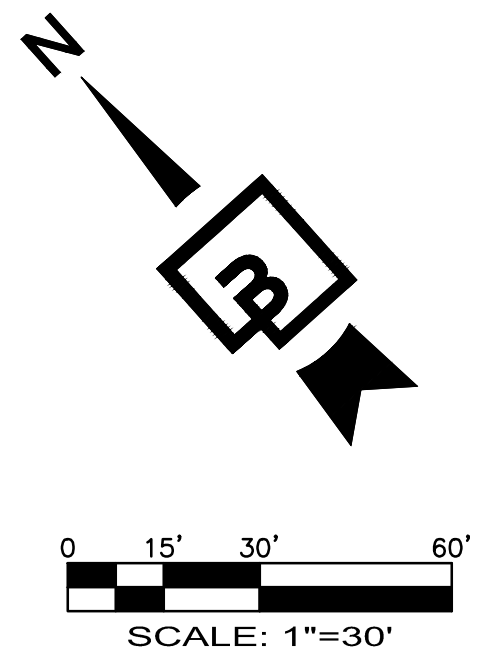



CHEHALIS INDUSTRIAL PARK

PORTIONS OF THE N.W. 1/4 AND THE S.W. 1/4 OF SEC. 11, TWN. 13 N., RG. 2 W., W.M.
LEWIS COUNTY, WASHINGTON

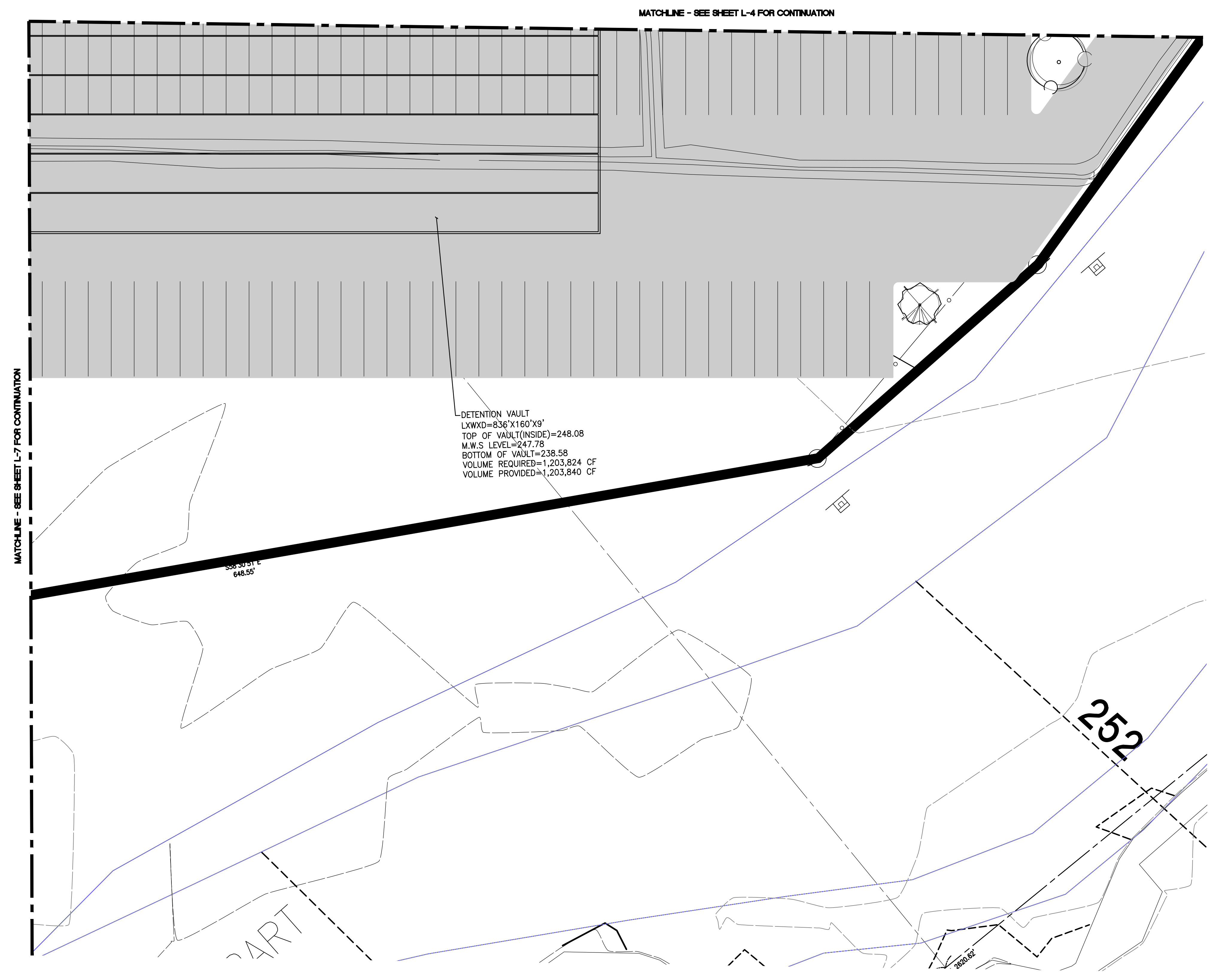
PRELIMINARY LANDSCAPE PLAN

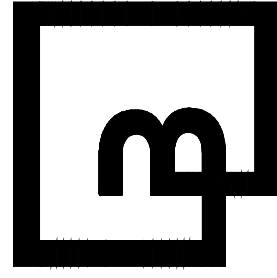

Job Number 14030	Sheet L-8 of 9	 <p>Barghausen Consulting Engineers, Inc. 18215 72nd Avenue South Kent, WA 98032 425.251.6222 barghausen.com</p>	<p>Designed <u> </u> .JMV. Drawn <u> </u> .JMV. Checked <u> </u> .JMV. Approved <u> </u> .JMV. Date <u> </u> 9/2/21</p>	<p>Scale: Horizontal 1"=30' Vertical N/A</p>		<p>For: PUGET WESTERN, INC. 20000 N CREEK PARKWAY BUILDING H BOTHELL, WA 98011</p>	<p>Title: PRELIMINARY LANDSCAPE PLAN FOR CHEHALIS INDUSTRIAL PARK</p>	<p>No. <u> </u> Date <u> </u> By <u> </u> Ckd. <u> </u> Appr. <u> </u> Revision <u> </u></p>
----------------------------	--------------------------	--	---	--	---	---	---	--

P:\14030a\14030\preliminary\14030-L.dwg 9/2/2021 11:40 AM JWARLEY

CHEHALIS INDUSTRIAL PARK

PORTIONS OF THE N.W. 1/4 AND THE S.W. 1/4 OF SEC. 11, TWN. 13 N., RG. 2 W., W.M.

LEWIS COUNTY, WASHINGTON

PRELIMINARY LANDSCAPE PLAN

PLANT SCHEDULE

SYMBOL	BOTANICAL/COMMON NAMES	SIZE CONDITION	SPACING	QUANTITY	REMARKS
TREES:					
	ZELKOVA SERRATA 'VILLAGE GREEN' / JAPANESE ZELKOVA	2" CAL. B & B	AS SHOWN ON PLAN		FULL AND MATCHING. STAKE AND GUY FOR ONE YEAR
	CALOCEDRUS DECURRENS / INCENSE CEDAR	6' HT. MIN. B & B	AS SHOWN ON PLAN		FULL AND MATCHING. STAKE AND GUY FOR ONE YEAR
	PSEUDOTSUGA MENZIESII / DOUGLAS FIR	6' HT. MIN. B & B	AS SHOWN ON PLAN		FULL AND MATCHING. STAKE AND GUY FOR ONE YEAR
	PINUS CONTORTA VAR. CONTORTA / SHORE PINE	6' HT. MIN. B & B	AS SHOWN ON PLAN		FULL AND MATCHING. STAKE AND GUY FOR ONE YEAR
	THUJA PLICATA / WESTERN RED CEDAR	5' HT. MIN. B & B	AS SHOWN ON PLAN		FULL AND MATCHING. STAKE AND GUY FOR ONE YEAR
NOTE FOR ALL DECIDUOUS TREES: FULL AND MATCHING. BRANCHING STARTS AT 6'. SINGLE LEADER UNLESS OTHERWISE NOTED HERE; GROWN FOR STREET TREE USE, STAKE AND GUY ONE GROWING SEASON					
SHRUBS:					
	ROSA NUTKANA / NOOTKA ROSE	2-GALLON	AS SHOWN		FULL, MIN. 3 STEMS, NATIVE
	PHYSOCARPUS CAPITATUS / PACIFIC NINEBARK	2-GALLON	AS SHOWN		FULL, NATIVE
	OEMLERIA CERASIFORMIS / INDIAN PLUM	2-GALLON	AS SHOWN		FULL, NATIVE
	MAHONIA AQUIFOLIUM / TALL OREGON GRAPE	2-GALLON	AS SHOWN		FULL, MIN. 3 STEMS, NATIVE
	VACCINIUM OVATUM / EVERGREEN HUCKLEBERRY	2-GALLON	AS SHOWN		FULL, NATIVE
	RIBES SANGUINEUM / RED FLOWERING CURRANT	2-GALLON	AS SHOWN		FULL, NATIVE
	SYMPHORICARPOS ALBUS / SNOWBERRY	2-GALLON	AS SHOWN		FULL, NATIVE
	MYRICA CALIFORNICA / PACIFIC WAX MYRTLE	2-GALLON	AS SHOWN		FULL, NATIVE
	CALAMAGROSTIS ACUTOFOLIA 'KARL FOERSTER' / REED FEATHER GRASS	1-GALLON	AS SHOWN		FULL AND BUSHY
	PENNISETUM ALOP. 'HAMELN' / FOUNTAIN GRASS	1-GALLON	AS SHOWN		FULL AND BUSHY
	NANDINA DOMESTICA 'MOON BAY' / NANDINA	2-GALLON	AS SHOWN		FULL AND BUSHY
	VIBURNUM DAVIDII / DAVID VIBURNUM	2-GALLON	AS SHOWN		FULL AND BUSHY
	HELICOTRICHON SEMPERVIRENS 'SAPPHIRE' / BLUE OAT GRASS	2-GALLON	AS SHOWN		FULL AND BUSHY
	EUONYMUS FORTUNEI 'EMERALD N GOLD' / EUONYMUS	2-GALLON	AS SHOWN		FULL AND BUSHY
GROUNDCOVERS:					
	EXISTING LANDSCAPING TO REMAIN. PROTECT DURING CONSTRUCTION				
	GAULTHERIA SHALLON	1 GAL.	48" O.C.	AS REQ'D	HOLD 24" FROM BORDERS, SHRUBS, AND TREES
	ARCTOSTAPHYLLOS 'MASSACHUSETTS' / KINNIKINNIK	1 GAL.	36" O.C.	AS REQ'D	HOLD 12" FROM BORDERS, SHRUBS, AND TREES
	VINCA MINOR / DWARF PERIWINKLE	1 GAL.	30" O.C.	AS REQ'D	HOLD 12" FROM BORDERS, SHRUBS, AND TREES

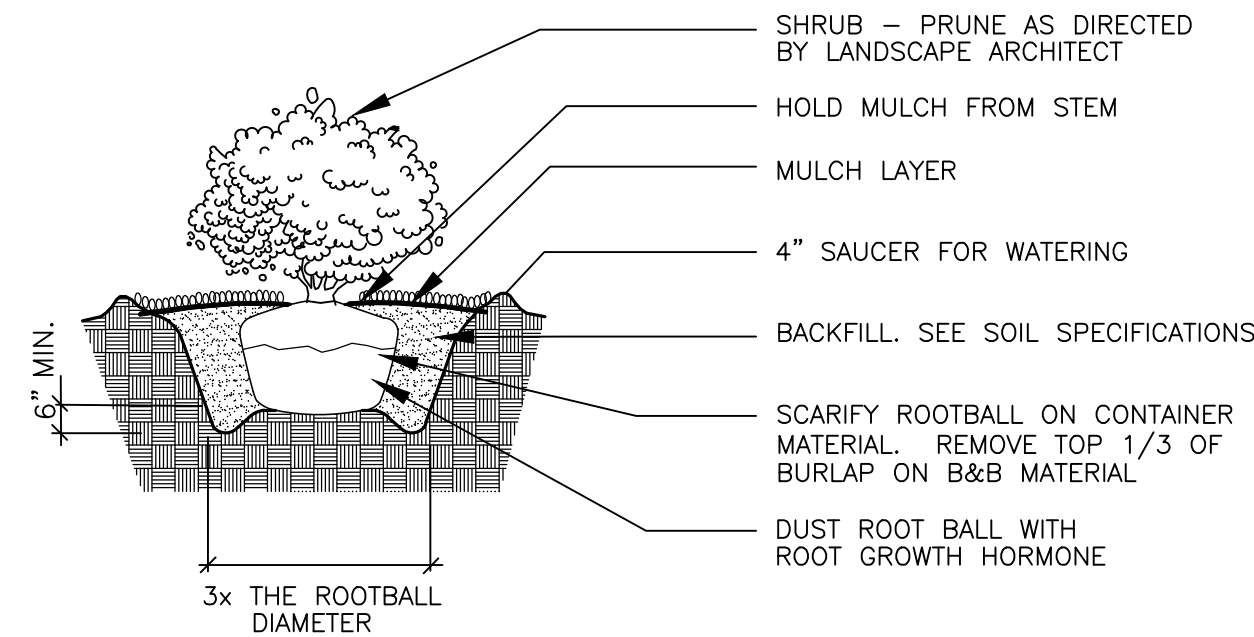

NOTE:
APPLY ADDITIONAL 4 OZ. 8-32-16 FERTILIZER INTO TOP 2" OF PLANTING MIX.
PLANT SHRUB HIGH ENOUGH TO ALLOW POSITIVE DRAINAGE AWAY FROM ROOTBALL. ROUGHEN ALL SURFACES OF PIT.

SHRUB PLANTING DETAIL

NOT TO SCALE

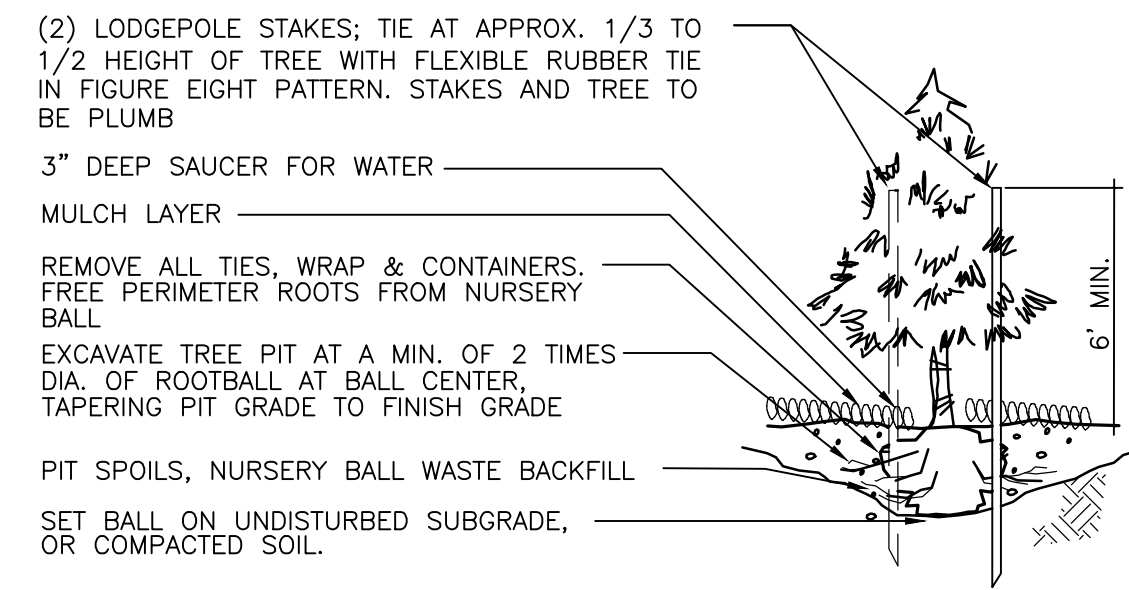

NOTE:
LIGHT FERTILIZER OVER PLANTING BED AFTER BACKFILL ONLY; NO FERTILIZER IN PLANTING PIT.
WORK PERIMETER ROOTS FREE OF NURSERY BALL. BALL & PIT TO BE COURSELY SCARIFIED.

EVERGREEN TREE PLANTING/STAKING DETAIL

NOT TO SCALE

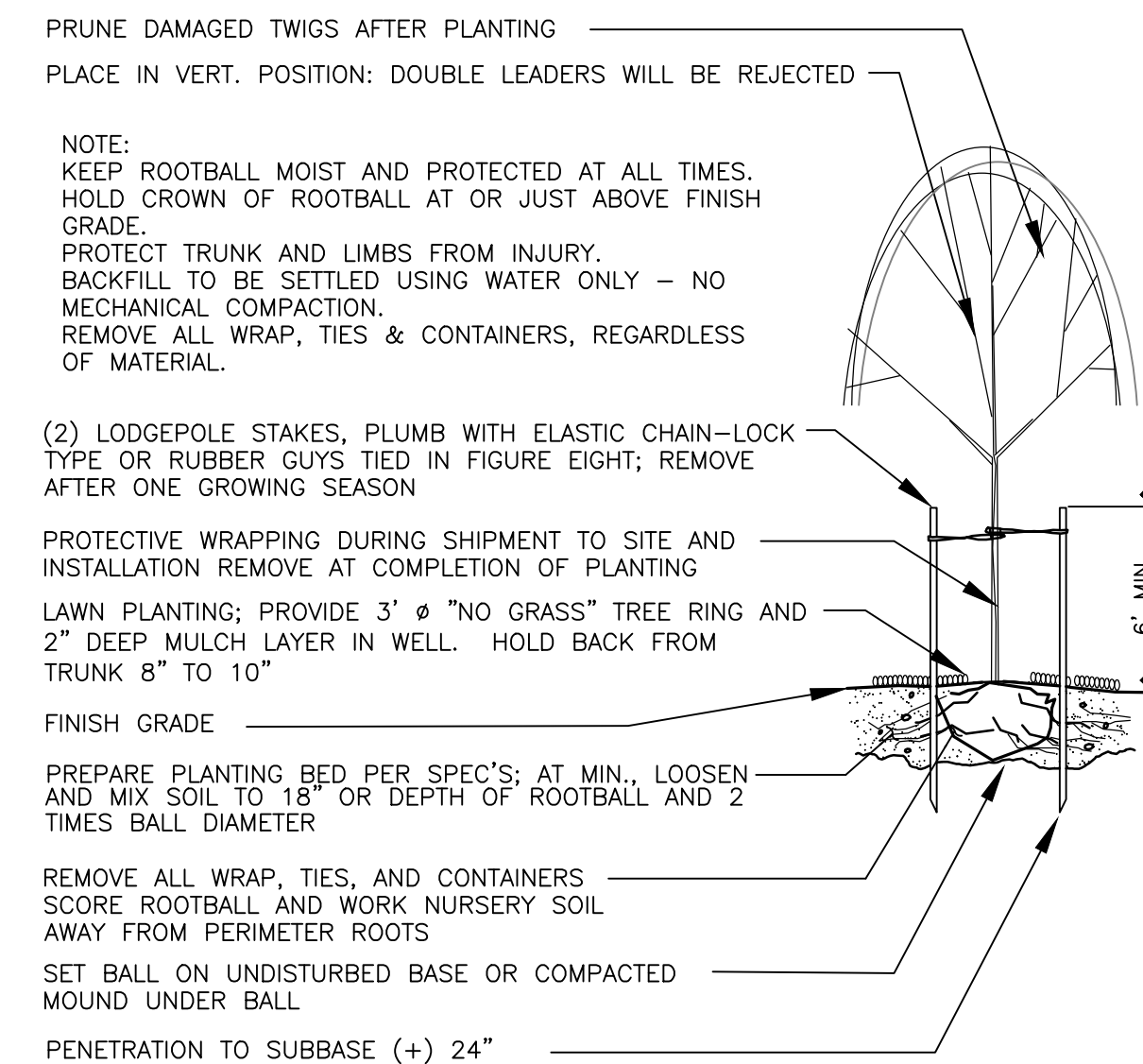

DECIDUOUS TREE PLANTING/STAKING DETAIL

NOT TO SCALE

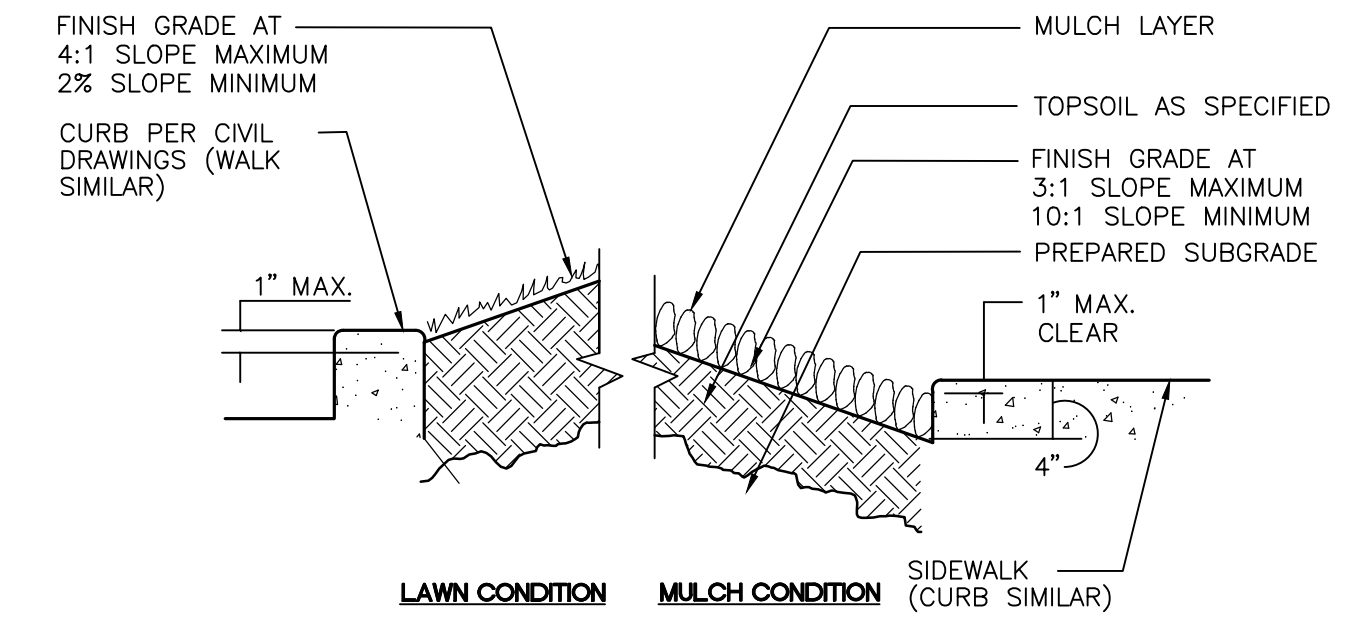

PLANTER SECTION DETAIL

NOT TO SCALE

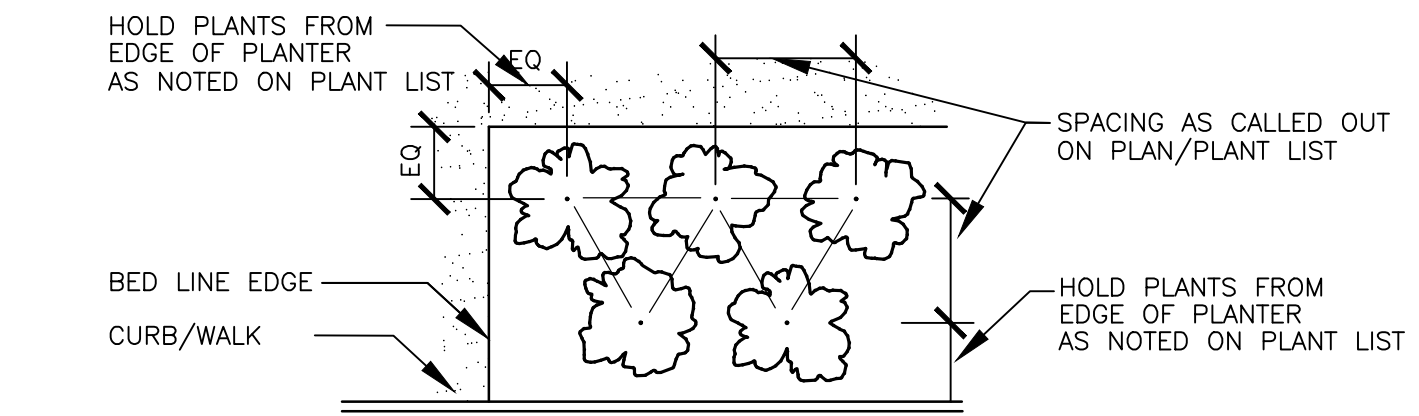

PLANT MATERIAL SPACING DETAIL

NOT TO SCALE

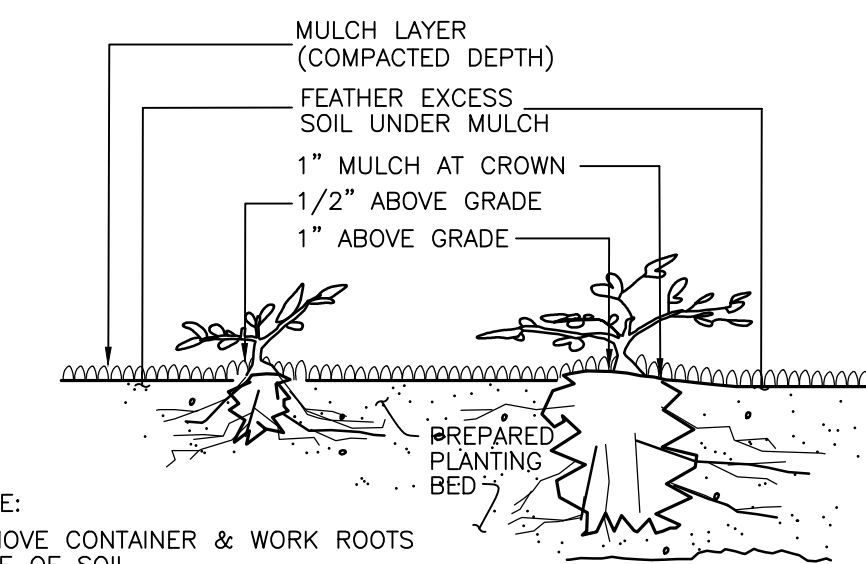

NOTE:
REMOVE CONTAINER & WORK ROOTS FREE OF SOIL.
BACKFILL TO BE SETTLED USING WATER ONLY.
SEE PLANT LIST FOR PLANT SPACING.

LESS THAN 1 GAL (PLANTED BEFORE MULCH) | 1 GAL CONTAINER and LARGER (PLANTED BEFORE MULCH)

GROUNDCOVER PLANTING DETAIL

NOT TO SCALE

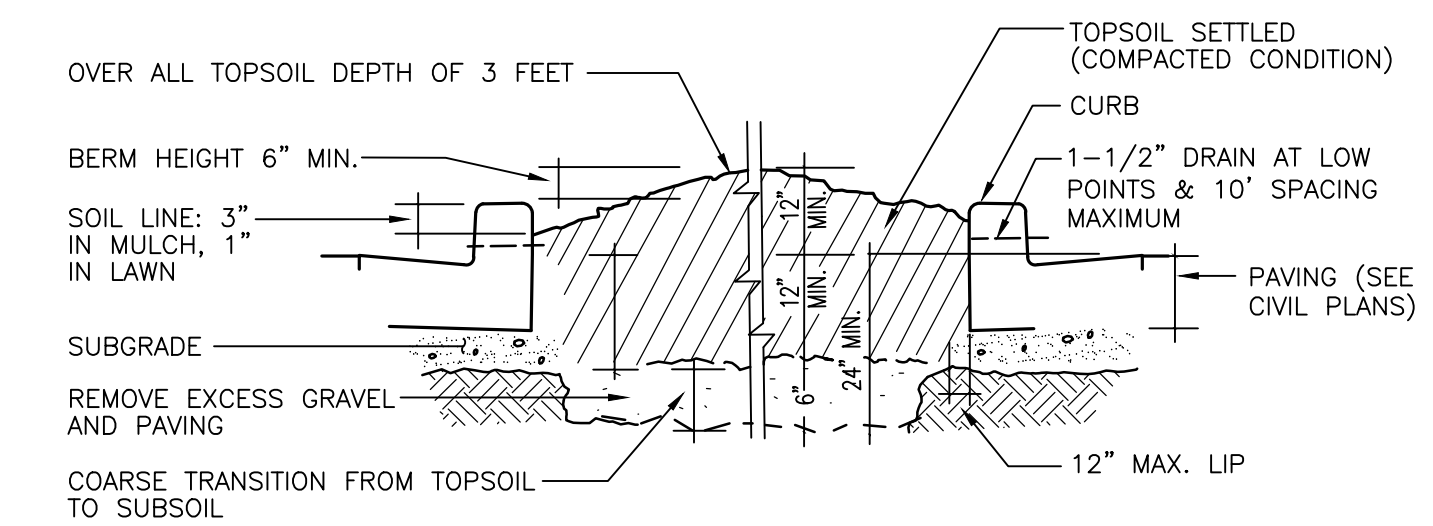

NOTE:
OVER EXCAVATE PARKING LOT PLANTERS TO LOOSEN COMPACTED SUBBASE

GRADING • PARKING LOT PLANTERS DETAIL

NOT TO SCALE

DEDUCT ALT #1: IF LANDSCAPE CONTRACTOR CAN DEMONSTRATE THAT PLANTER ISLANDS ARE NOT FULL OF NON-SOIL MATERIALS (CONCRETE WASTE, LUMBER, ROAD BASE, GRAVEL), FULL EXCAVATION AND REPLACE WITH 18"-21" OF TOPSOIL CAN BE ELIMINATED AND IN ITS PLACE, 6" OF COMPOST CAN BE PLACED ON SUB-GRADE AND CULTIVATED INTO TOP 12" OF EXISTING SOIL. TOP OF FINISH GRADE AND DEPTH OF MULCH STILL APPLIES

Revision
Appr.
By
Date

PRELIMINARY LANDSCAPE PLAN
FOR
CHEHALIS INDUSTRIAL PARK

For:
PUGET WESTERN, INC.
20000 N CREEK PARKWAY
BUILDING H
BOTHELL, WA 98011

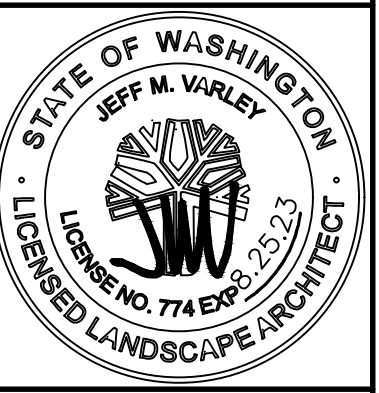

Scale:
Horizontal 1"=30'
Vertical N/A

Designed: JMV
Drawn: JMV
Checked: JMV
Approved: JMV
Date: 9/2/21

Barghausen Consulting Engineers, Inc.
18215 72nd Avenue South
Kent, WA 98032
425.251.6222
barghausen.com

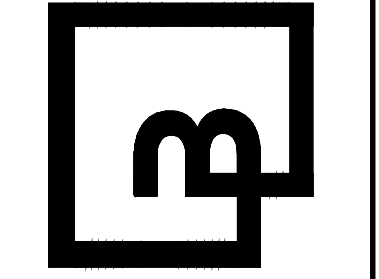

Job Number
14030
Sheet
L-9 of 9